

# BUTTERFLY VALVE GEAR OPERATOR FULL FLANGED TYPE



## MATERIALS OF CONSTRUCTION

No.	Parts	Pcs.	Materials	No.	Parts	Pcs.	Materials
1	Body	1	UPVC, PP,CPVC, PPG, PVDF	11	Indicator Plate	1	PVC
2	Seat	1	EPDM, VITON, NBR, HYPALON	12	Gear	1	FCD45
3	Disc	1	UPVC, PP,CPVC, PPG, PVDF	13	Oil Seal	1	EPDM
4	Disc O'ring(A)	2	EPDM, VITON	14	Bearing	1	SMCM220/420/810
5	Disc O'ring(B)	2	EPDM, VITON	15	Adjustable Bolt	2	SS41
6	Stem	1	SUS410, SUS304, SUS316	16	Gearing	1	SS41
7	Stem O'ring	2	EPDM, VITON	17	Set Pin	1	K7
8	Gear Box	1	FC25	18	Hand Wheel	1	FC25
9	Gear Box Cap	1	FC25	19	Tightening Bolt	4	SCM3,SUS304
10	Side Cap	1	FC25				

# Dimensions Table

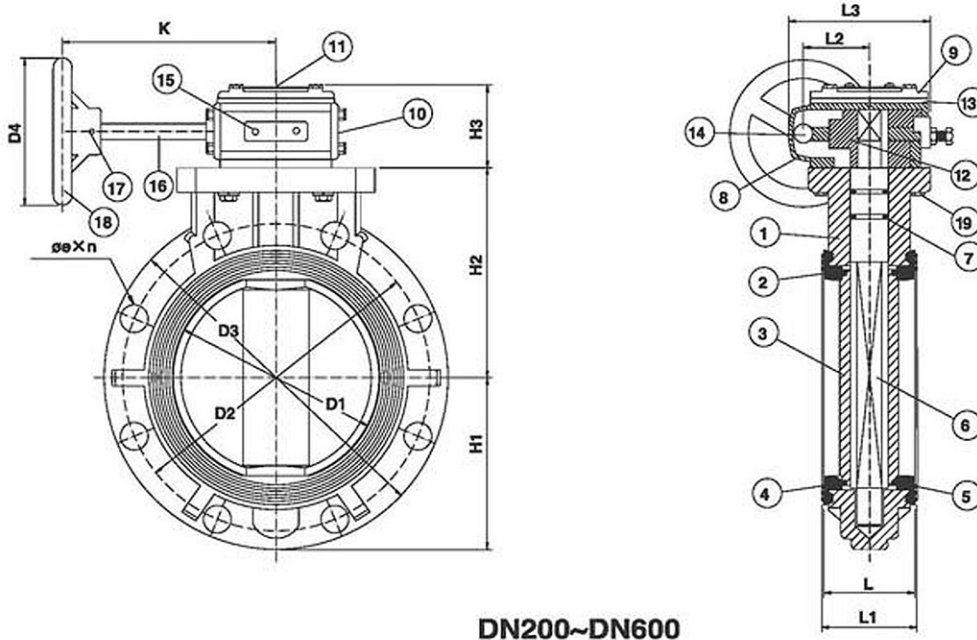

## DIMENSIONS TABLE

JIS																Unit: mm	
Nom. Size DN(Inch)	D1	D2	n	øe	D3	L	L1	H1	H2	H3	K	L2	L3	D4	Test Press (kgf/cm <sup>2</sup> )		Working Press (kgf/cm <sup>2</sup> )
															Body	Seat	
200(8")	203	290	12	23	337	76	87	168	204	69	178	51	136	178	15.0	12.0	10.0
250(10")	255	355	12	25	400	96	111	200	235	69	178	51	136	178	15.0	12.0	10.0
300(12")	312	400	16	25	483	116	132	239	289	103	216	72	189	305	10.5	8.5	7.0
350(14")	355	445	16	25	520	116	132	259	305	103	216	72	189	305	10.5	8.5	7.0
400(16")	398	510	16	27	600	153	169	302	353	103	232.2	72	189	355.6	9.0	7.0	6.0
450(18")	451	565	20	27	640	166	181	317	365	121	280.2	116	285	460.4	7.5	6.0	5.0
500(20")	500	620	20	27	711	171	190	365	405	121	318.8	116	285	457.2	5.0	4.0	3.5
600(24")	600	730	24	33	813	191	209	425	460	121	330	116	285	508	5.0	4.0	3.5

ANSI																Unit: inch	
Nom. Size DN(Inch)	D1	D2	n	øe	D3	L	L1	H1	H2	H3	K	L2	L3	D4	Test Press (lb/in <sup>2</sup> )		Working Press (lb/in <sup>2</sup> )
															Body	Seat	
200(8")	7.99	11.75	8	0.88	13.27	2.99	3.43	6.61	8.03	2.72	7.01	2.01	5.35	7.01	222	177	150
250(10")	10	14.25	12	0.98	15.75	3.78	4.37	7.87	9.25	2.72	7.01	2.01	5.35	7.01	222	177	150
300(12")	12.28	17.00	12	0.98	19.02	4.57	5.20	9.41	11.38	4.05	8.50	2.83	7.44	12	155	125	105
350(14")	13.97	18.75	12	1.14	20.47	4.57	5.20	10.20	12.01	4.05	8.50	2.83	7.44	12	155	125	105
400(16")	15.69	21.25	16	1.14	23.62	6.02	6.65	11.89	13.90	4.05	8.78	2.83	7.44	14	133	103	88
450(18")	17.75	22.75	16	1.26	25.20	6.54	7.13	12.48	14.37	4.76	11.03	4.57	11.22	16	111	88	74
500(20")	19.70	25.00	20	1.26	27.99	6.73	7.48	14.37	15.94	4.76	12.55	4.57	11.22	18	74	59	52
600(24")	23.66	29.50	20	1.38	32.00	7.52	8.23	16.73	18.11	4.76	12.99	4.57	11.22	20	74	59	52

DIN																Unit: mm	
Nom. Size DN(Inch)	D1	D2	n	øe	D3	L	L1	H1	H2	H3	K	L2	L3	D4	Test Press (kgf/cm <sup>2</sup> )		Working Press (kgf/cm <sup>2</sup> )
															Body	Seat	
200(8")	203	295	8	23	337	76	87	168	204	69	178	51	136	178	15.0	12.0	10.0
250(10")	255	350	12	25	400	96	111	200	235	69	178	51	136	178	15.0	12.0	10.0
300(12")	312	400	12	25	483	116	132	239	289	103	216	72	189	305	10.5	8.5	7.0
350(14")	355	460	16	25	520	116	132	259	305	103	216	72	189	305	10.5	8.5	7.0
400(16")	398	515	16	27	600	153	169	302	353	103	232.2	72	189	355.6	9.0	7.0	6.0
450(18")	451	565	20	27	640	166	181	317	365	121	280.2	116	285	460.4	7.5	6.0	5.0
500(20")	500	620	20	27	711	171	190	365	405	121	318.8	116	285	457.2	5.0	4.0	3.5
600(24")	600	725	20	30	813	191	209	425	460	121	330	116	285	508	5.0	4.0	3.5

※ Standard dimensions based on UPVC material